

# Efficient USB communication under GNU/Linux for a wideband L-band (GNSS) SDR receiver: processing GNSS signals

J.-M Friedt

FEMTO-ST Time & Frequency, Besançon, France

From

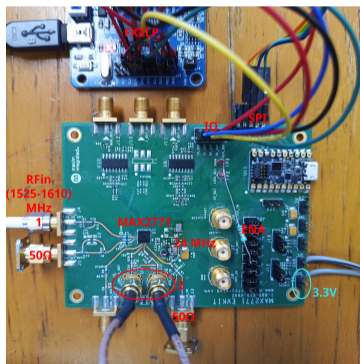

to

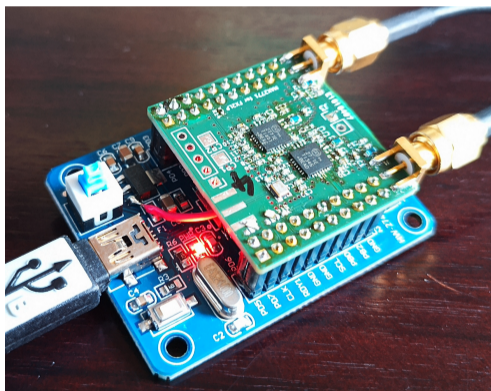

February 25, 2026

# GPS L1 BPSK decoding

- ▶ chip rate is 1.023 Mchips/s BPSK with code sequences documented at <https://github.com/danipascual/GNSS-matlab> & <https://github.com/pmonta/GNSS-DSP-tools> (Python)
- ▶ frequency offset  $df$  prevents energy accumulation when cross-correlating signal and code if  $df \geq 1/T$  with  $T$  the code duration
- ▶ **acquisition**: search for all possible  $df$  with step  $\ll 1/T$  in the range of possible frequency shift ( $\pm 4$  kHz from Doppler shift + LO offset) ...
- ▶ ... for all (32) possible code sequences

$$xcorr(s, p_i \cdot \exp(j2\pi df_j t)) \text{ for } i \in [1..32] \text{ and } df_j \in [???]$$

- ▶ leads to a frequency-code map with correlation maximum encoding each pixel color

Galileo 2 MHz  
GPS 2 MHz  
Galileo 15 MHz

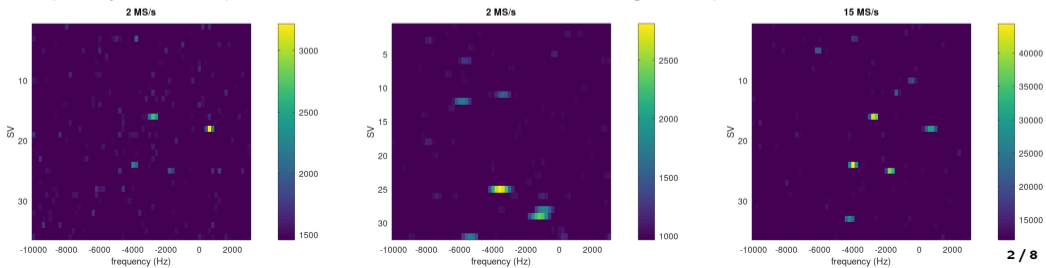

# GNSS modulations

BOC( $f_s/f_0, f_c/f_0$ ): Binary Offset Carrier ( $f_0$  ref freq.,  $f_s$  subcarrier freq.,  $f_c$  chip rate)

System	Carrier [MHz]	Signal	Type	Modulation	Chipping rate	Code Length	Full length [ms]
GPS	L1 1575.420	C/A	Data	BPSK	1.023Mcps	1023	1
	L5 1176.450	I	Data	QPSK	10.23Mcps	10230	1
		Q	Pilot		10.23Mcps	10230	1
Galileo	E1 1575.42	B	Data	BOC(1,1)	1.023Mcps	4092 * 1	4
		C	Pilot		1.023Mcps	4092 * 25	100
	E5 a:1176.450	a-I	Data	AltBOC(15,10)	10.23Mcps	10230 * 20	20
		a-Q	Pilot		10.23Mcps	10230 * 100	100

“The minimum bandwidth is generally twice the chipping rate for simple codes, while for BOC codes it is twice the sum of chipping rate and offset code rate. Thus, the minimum practical bandwidth for the Galileo E1 is 8 MHz.”<sup>1</sup>

<sup>1</sup>K. Borre Lecture at SU May 27, 2009, *The E1 Galileo Signal* at

[http://web.stanford.edu/group/scpnt/gpslab/pubs/papers/Borre/galileo\\_sig.pdf](http://web.stanford.edu/group/scpnt/gpslab/pubs/papers/Borre/galileo_sig.pdf)

# Galileo E1 BOC decoding

## ► BPSK modulation of pseudo-random sequences (Gold codes <sup>2</sup>)

```
load GNSS-matlab/prn_codes/codes_L1CA.mat;
code=interpolated(codes_L1CA(:,m),fs/1.023e6);
% 0/pi phase at baseband
```

## ► BOC modulation of pseudo-random sequences

```
load GNSS-matlab/prn_codes/codes_E1B.mat
Rsa=1.023e6;
Rsb=6.138e6;
m=1;
code=interpolated(codes_E1B(:,m),fs/1.023e6);
temps=[0:length(code)-1]'/fs;
scea=sqrt(10/11)*((sin(2*pi*temps*Rsa)>0)*2-1);
sceb=sqrt(1/11)*((sin(2*pi*temps*Rsb)>0)*2-1);
signal=(scea+sceb).*code;
```

See “Galileo open service signal-in-space interface control document (OS SIS ICD)” at [https://www.gsc-europa.eu/sites/default/files/sites/all/files/Galileo\\_OS\\_SIS\\_ICD\\_v2.1.pdf](https://www.gsc-europa.eu/sites/default/files/sites/all/files/Galileo_OS_SIS_ICD_v2.1.pdf) (courtesy of C. Plantard, ESTEC)

E1 Signal

Figure 7 provides a generic view of the E1 CBOC signal generation.

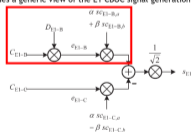

Figure 7: Modulation Scheme for the E1 CBOC Signal

The E1 CBOC signal components are generated as follows:

- $e_{E1-B}$  from the I/NAV navigation data stream  $D_{E1-B}$  and the ranging code  $C_{E1-B}$  then modulated with the sub-carriers  $s_{C_{E1-B,a}}$  and  $s_{C_{E1-B,b}}$

The E1-B/C composite signal is then generated according to equation Eq. 11 below, with the binary signal components  $e_{E1-B}(t)$  and  $e_{E1-C}(t)$ . Note that as for E6, both pilot and data components are modulated onto the same carrier component, with a power sharing of 50 percent.

$$s_{E1}(t) = \frac{1}{\sqrt{2}} \left[ e_{E1-B}(t) (\alpha s_{C_{E1-B,a}}(t) + \beta s_{C_{E1-B,b}}(t)) - e_{E1-C}(t) (\alpha s_{C_{E1-C,a}}(t) - \beta s_{C_{E1-C,b}}(t)) \right] \quad \text{Eq. 11}$$

with  $s_{C_X}(t) = \text{sgn}(\sin(2\pi R_{s,X} t))$

The parameters  $\alpha$  and  $\beta$  are chosen such that the combined power of the  $s_{C_{E1-B,b}}$  and the  $s_{C_{E1-C,b}}$  sub carrier components equals 1/11 of the total power of  $e_{E1-B}$  plus  $e_{E1-C}$ , before application of any bandwidth limitation. This yields:

$$e_{E1-B}(t) = \sum_{i=-\infty}^{\infty} \left[ C_{E1-B,|i|L_{E1-B}} D_{E1-B,|i|D_{C_{E1-B}}} \text{rect}_{T_{C,E1-B}}(t - iT_{C,E1-B}) \right] \quad \text{Eq. 10}$$

$$e_{E1-C}(t) = \sum_{i=-\infty}^{\infty} \left[ C_{E1-C,|i|L_{E1-C}} \text{rect}_{T_{C,E1-C}}(t - iT_{C,E1-C}) \right]$$

Galileo satellites transmit ranging signals for the E1 signal with the chip rates and sub-carrier rates defined in the following Table 9.

Table 9: E1 CBOC Chip Rates and Sub-carrier Rates

Component (Parameter Y)	Sub-carrier Type	Sub-carrier Rate		Ranging Code Chip-Rate $R_{C,E1-Y}$ (Mcps)
		$R_{S,E1-Y,a}$ (MHz)	$R_{S,E1-Y,b}$ (MHz)	
B	CBOC, in-phase	1.023	6.138	1.023
C	CBOC, anti-phase	1.023	6.138	1.023

All PRN sequences at

<https://github.com/danipascual/GNSS-matlab>

The navigation data message stream, after channel encoding, is transmitted with the symbol rate as stated in Table 10.

# Galileo E5 AltBOC decoding

“The Alternative BOC modulation uses a complex sub-carrier so that the spectrum is not split up, as is the case of BOC, but simply shifted to higher or lower frequencies”<sup>a</sup>

⇒ [https://github.com/danipascual/GNSS-matlab/tree/master/prn\\_codes](https://github.com/danipascual/GNSS-matlab/tree/master/prn_codes) lists E5aI and E5aQ, and E5bI and E5bQ.

However, <https://gnss-sdr.org/docs/tutorials/gnss-signals/> refers to E5a as QPSK(10), i.e. 4-phase states at  $10 \times 1.023 = 10.23$  MHz

<sup>a</sup>[https://gssc.esa.int/navipedia/index.php/AltBOC\\_Modulation](https://gssc.esa.int/navipedia/index.php/AltBOC_Modulation)

Signal (Parameter X)	Component (Parameter Y)	Ranging Code Chip-Rate $R_{C,X-Y}$ (Mchip/s)	Symbol-Rate $R_{D,X-Y}$ (symbols/s)
E5a	I	10.230	50
	Q	10.230	No data ('pilot component')
E5b	I	10.230	250
	Q	10.230	No data ('pilot component')

## Modulation Type

The wideband E5 signal is generated with the AltBOC modulation of side-band sub-carrier rate  $R_{S,E5} = 1 / T_{S,E5} = 15.345$  MHz ( $15 \times 1.023$  MHz) according to the expression in Eq. 2 with the binary signal components  $e_{E5a-I}$ ,  $e_{E5a-Q}$ ,  $e_{E5b-I}$  and  $e_{E5b-Q}$  as defined in Eq. 3.

Note that E5a and E5b signals can be processed independently by the user receiver as though they were two separate QPSK signals with a carrier frequency of 1176.45 MHz and 1207.14 MHz respectively.

$$\begin{aligned}
 s_{E5}(t) = & \frac{1}{2\sqrt{2}} \left( e_{E5a-I}(t) + j e_{E5a-Q}(t) \right) \left[ s_{C_{E5-S}}(t) - j s_{C_{E5-S}} \left( t - \frac{T_{S,E5}}{4} \right) \right] + \\
 & \frac{1}{2\sqrt{2}} \left( e_{E5b-I}(t) + j e_{E5b-Q}(t) \right) \left[ s_{C_{E5-S}}(t) + j s_{C_{E5-S}} \left( t - \frac{T_{S,E5}}{4} \right) \right] + \\
 & \frac{1}{2\sqrt{2}} \left( \bar{e}_{E5a-I}(t) + j \bar{e}_{E5a-Q}(t) \right) \left[ s_{C_{E5-P}}(t) - j s_{C_{E5-P}} \left( t - \frac{T_{S,E5}}{4} \right) \right] + \\
 & \frac{1}{2\sqrt{2}} \left( \bar{e}_{E5b-I}(t) + j \bar{e}_{E5b-Q}(t) \right) \left[ s_{C_{E5-P}}(t) + j s_{C_{E5-P}} \left( t - \frac{T_{S,E5}}{4} \right) \right]
 \end{aligned} \tag{Eq. 3}$$

“Galileo open service signal-in-space interface control document (OS SIS ICD)” page 20

**L1 C/A**  
1575.42 MHz  
30 MS/s

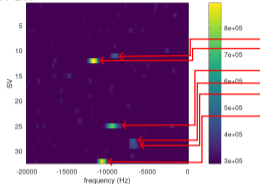

ID	GNSS	CF	C/N0	Flags	Elev	Azim
6	L1	L1	32.6	AEU	21°	48°
11	L1	L1	27.2	AEU	28°	83°
12	L1	L1	35.8	AEU	58°	66°
24	L1	L1	18.4	AEU	25°	143°
25	L1	L1	35.4	AEU	75°	305°
28	L1	L1	41.5	AEU	30°	308°
29	L1	L1	43.5	AEU	40°	202°
31	L1	L1	30.6	AEU	6°	309°
32	L1	L1	41.7	AEU	37°	267°
6	L1	L1	29.5	AEU	21°	252°
7	L1	L1	31.8	AEU	28°	304°
8	L1	L1	30.7	AEU	8°	349°
9	L1	AE	24°		298°	
15	L1	L1	23.4	AEU	34°	88°
16	L1	L1	28.2	AEU	68°	1°
17	L1	L1	24.3	AEU	45°	57°
18	L1	L1	34.0	AEU	46°	133°
19	L1	L1	24.5	AEU	15°	167°
24	L1	L1	23.5	AEU	5°	19°
3	E1	E1	29.2	A U	35°	297°
5	E1	E1	33.7	A U	40°	230°
8	E1	E1		A	2°	336°
9	E1	E1	14.2	A U	9°	184°
10	E1	E1	13.5	A U	13°	142°
12	E1	E1	14.7	A U	23°	120°
14	E1	E1	37.1	U	55°	189°
16	E1	E1	35.5	A U	63°	281°
24	E1	E1	16.1	A U	80°	13°
25	E1	E1	29.1	A U	38°	270°
26	E1	E1	22.5	A	4°	18°
31	E1	E1	24.3	A U	31°	75°
33	E1	E1	30.6	A U	26°	61°
5	B1	B1		A	14°	120°
10	B1	B1	17.8	A U	12°	56°
14	B1	B1	28.0	A U	14°	310°
21	B1	B1	38.0	A U	7°	236°
26	B1	B1	22.0	A U	42°	296°
29	B1	B1	42.0	A U	56°	116°
30	B1	B1	22.4	A U	27°	48°
33	B1	B1	31.3	A U	7°	334°
35	B1	B1	32.3	U	22°	184°
36	B1	B1	15.1	U	26°	108°
42	B1	B1	35.9	U	16°	283°
45	B1	B1	35.9	U	76°	88°
60	B1	B1			2°	102°

**E1B**  
30 MS/s

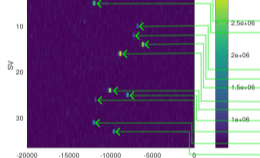

**E1C**  
30 MS/s

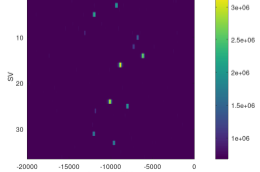

ID	SBAS	CF	C/N0	Flags	Elev	Azim
123	L1	L1			33°	156°
136	L1	L1	40.0		35°	181°
128	L1	L1				99°

Lat: 47.2516233°  
Long: 5.9929483°  
Alt: 344.0 m  
Alt (MSL): 296.0 m  
Speed: 0.1 m/s  
S. Acc: 0.4 m/s  
PDOP: 0.7

Time: 10:58:38  
TTFF: 2 sec  
E H/V Acc: 1.3/10.4 m  
# Sats: 39/41/48  
Bearing: 177.5°  
B. Acc: 179.9°  
H/V DOP: 0.4/0.5

**L5I**

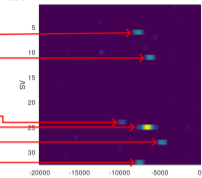

**L5Q**

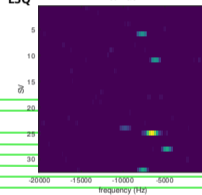

**L5I-jL5Q**

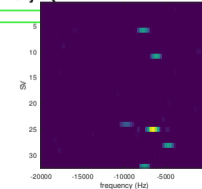

**1176.45 MHz**

**E5aI**

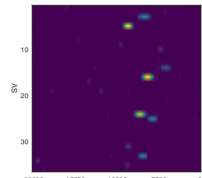

**E5aQ**

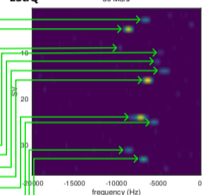

**E5aI-jE5aQ**

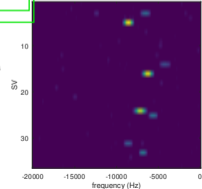

# Galileo & GPS

- ▶ How much bandwidth is needed for GPS L1?
- ▶ How much bandwidth is needed for Galileo E1?
- ▶ What is the minimum bandwidth for assessing Galileo E1?
- ▶ Impact of the longer Galileo code on resulting SNR?
- ▶ Impact of the longer Galileo code on frequency step? for E1B and E1C?
- ▶ How to resample the code to match the acquisition sampling rate?
- ▶ Why is AltBOC analyzed as a QPSK (or 2 orthogonal BPSK) signal?

**Naming convention:** all frequencies referred to 1.023 MHz, so that BPSK(10) is 10.23 MHz and BOC(1,1) means a chiprate of 1.023 MHz with a binary frequency offset of 1.023 MHz.

## References

- ▶ K. Borre, D.M. Akos, N. Bertelsen, P. Rinder, S.H. Jensen, *A Software-Defined GPS and Galileo Receiver – A Single-Frequency Approach*, Birkhäuser (2007)
- ▶ K. Borre, I. Fernández-Hernández, J.A. López-Salcedo, M.Z.H. Bhuiyan, *GNSS Software Receivers*, Cambridge University Press (2023)
- ▶ E.D. Kaplan & C. Hegarty, *Understanding GPS/GNSS – principles and applications*, Artech House (2017)
- ▶ A. Flores, *RFC-00413* at <https://www.gps.gov/technical/icwg/IS-GPS-705H.pdf>
- ▶ Galileo open service signal-in-space interface control document (OS SIS ICD) at [https://www.gsc-europa.eu/sites/default/files/sites/all/files/Galileo\\_OS\\_SIS\\_ICD\\_v2.1.pdf](https://www.gsc-europa.eu/sites/default/files/sites/all/files/Galileo_OS_SIS_ICD_v2.1.pdf)
- ▶ GPS Signal Plan at [https://gssc.esa.int/navipedia/index.php/GPS\\_Signal\\_Plan](https://gssc.esa.int/navipedia/index.php/GPS_Signal_Plan)
- ▶ Galileo Signal Plan at [https://gssc.esa.int/navipedia/index.php/Galileo\\_Signal\\_Plan](https://gssc.esa.int/navipedia/index.php/Galileo_Signal_Plan)
- ▶ GNSS Signals at <https://gnss-sdr.org/docs/tutorials/gnss-signals/>
- ▶ GNSS receiver on the Moon (Blue Ghost mission – landed March 2, 2025), see <https://www.gpsworld.com/nasa-and-italian-space-agency-demonstrate-lunar-gnss-payload/> and <https://blogs.nasa.gov/artemis/2025/01/21/blue-ghost-conducts-first-burn-science-operations-captures-eclipse/>  
“the Lunar GNSS Receiver Experiment (LuGRE) technology demonstration acquired Global Navigation Satellite System (GNSS) signals, and calculated a navigation fix at nearly 52 Earth radii: more than 205,674 miles (331,000 kilometers) from Earth’s surface”: **datasets available from** <https://zenodo.org/records/16411687>

Sample files in `/home/jmfriedt/gnss/out*` described with the SigMF format