

Radio logicielle 1/4 : introduction et prise en main de GNU Radio

J.-M Friedt

FEMTO-ST/département temps-fréquence, Besançon

`jmfriedt@femto-st.fr`

transparents et ressources à `jmfriedt.free.fr`

13 mars 2026

Radio Data System (RDS)

Station FM commerciale :

- ▶ audio G+D 0 – 19 kHz
- ▶ stereo? tone continu à 19 kHz
- ▶ audio G-D 19 – 39 kHz
- ▶ **RDS** : modulation BPSK centrée sur une sous-porteuse à 57 kHz
- ▶ Documenté dans EN 50067 "*Specification of the radio data system (RDS) for VHF/FM sound broadcasting in the frequency range from 87,5 to 108,0 MHz*"¹ (1998)

Plan de travail :

- ▶ isoler une station commerciale FM du flux IQ enregistré
- ▶ démoduler le signal FM
- ▶ identifier le signal RDS
- ▶ isoler le signal RDS (transposition de fréquence et filtrage)
- ▶ synchronisation des symboles numériques
- ▶ compensation de l'écart de fréquence récepteur/émetteur (BPSK)
- ▶ synchronisation du flux (CRC/SyncWord)

1. http://jmfriedt.free.fr/EN50067_RDS_Standard.pdf

Isoler une station FM

- ▶ Démodulateur FM est une boucle à verrouillage de phase (PLL)
- ▶ Version numérique du démodulateur FM² :

$$X(t) = A \cdot \exp(j\Delta\omega \cdot t + j\varphi(t)) \text{ avec } \varphi(t) = D \int_{-\infty}^t m(\tau) d\tau$$

alors

$$X_n \cdot X_{n+1}^* = A \cdot \exp\left(j\Delta\omega \cdot T_s + jD \int_{n \cdot T_s}^{(n+1) \cdot T_s} m(\tau) d\tau\right)$$

et

$$\int_{n \cdot T_s}^{(n+1) \cdot T_s} m(\tau) d\tau \simeq T_s \cdot m(n \cdot T_s) \text{ (rectangle)}$$

tel que

$$\arg(X_n \cdot X_{n+1}^*) = \underbrace{\Delta\omega \cdot T_s}_{\text{offset}} + \underbrace{D \cdot T_s}_{\text{gain}} \cdot m(n \cdot T_s)$$

- ▶ seule la station la plus puissance est démodulée (*FM capture*³)
- ▶ filtrer et visualiser

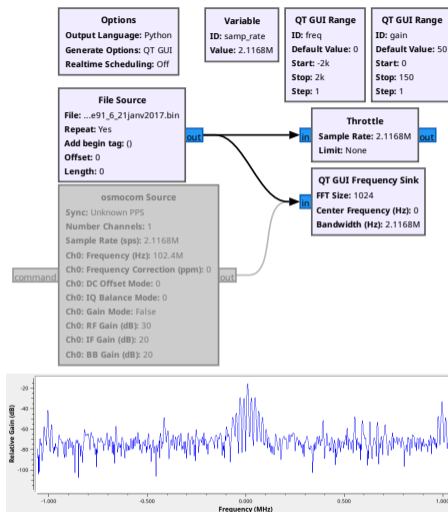

3. D. Bederov, *Arithmetic based implementation of a quadrature FM Demodulator*, à https://fosdem.org/2015/schedule/event/sdr_arithmetic/

3. J.- M Friedt, *La peinture sur spectre radiofréquence, et l'effet capture de la modulation en fréquence – ou pourquoi les avions communiquent encore en AM*, GNU/Linux Magazine France 216 (Juin 2018)

Transposer et isoler le signal RDS

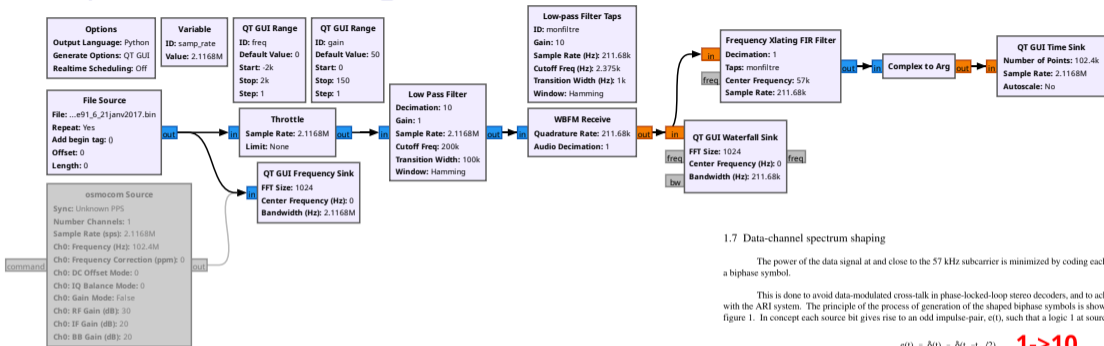

1.7 Data-channel spectrum shaping

The power of the data signal at and close to the 57 kHz subcarrier is minimized by coding each source data bit as a biphasse symbol.

This is done to avoid data-modulated cross-talk in phase-locked-loop stereo decoders, and to achieve compatibility with the ARI system. The principle of the process of generation of the shaped biphasse symbols is shown schematically in figure 1. In concept each source bit gives rise to an odd impulse-pair, $e(t)$, such that a logic 1 at source gives:

$$e(t) = \delta(t) - \delta(t - t_d / 2) \quad \mathbf{1 \rightarrow 10} \quad (1)$$

and a logic 0 at source gives:

$$e(t) = -\delta(t) + \delta(t - t_d / 2) \quad \mathbf{0 \rightarrow 01} \quad (2)$$

- ▶ Sous-porteuse à $3 \times 19 = 57$ kHz
- ▶ Transposition de fréquence (+57 ou -57 kHz puisque démodulation FM est réelle)
- ▶ Filtrage (cf bitrate : $57/48 = 1,1875$ kbits/s) mais codage différentiel Manchester (1 → 10 et 0 → 01) donc 1 bit en entrée pour 2 bits en sortie ($1,1875 \times 2 = 2.375$ kHz, premier null du spectre)
- ▶ Modulation en phase

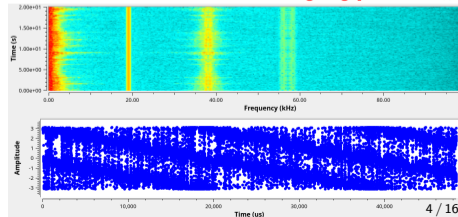

Modulation de phase

- ▶ PSK : *Phase Shift Keying*
- ▶ $\varphi = \arctan(Q/I)$: sortie du démodulateur IQ
- ▶ stabilité de l'oscillateur local : diagramme de constellation
- ▶ RDS, GPS : BPSK (*Binary Phase Shift Keying*) – démonstration avec un mélangeur saturé commandé par les bits à transmettre

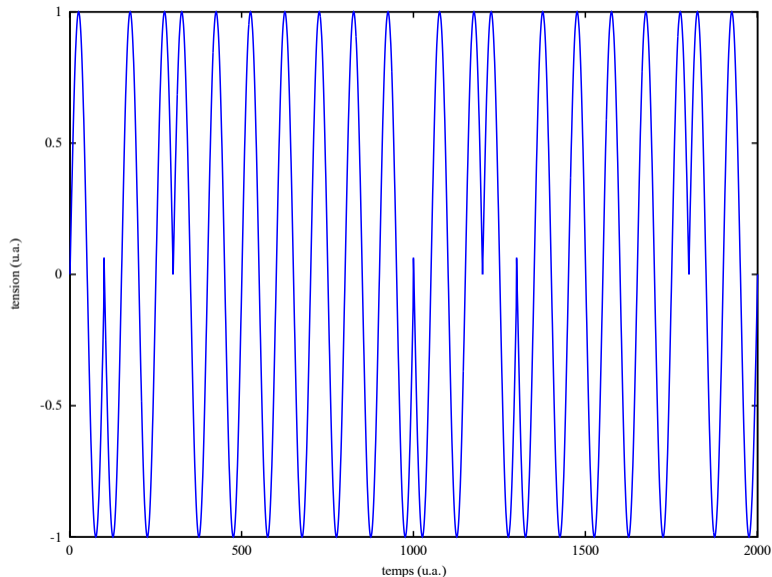

Démodulation de phase

Nécessite une reproduction de la porteuse non-modulée

$$\exp(j(\Delta\omega t + \varphi))^N = \exp(j(N\Delta\omega t + N\varphi)) = \exp(jN\Delta\omega t) \text{ if } \varphi = 2\pi \cdot n/N$$

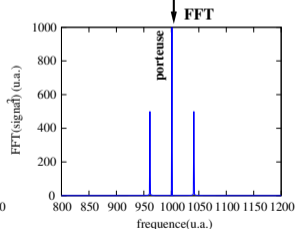
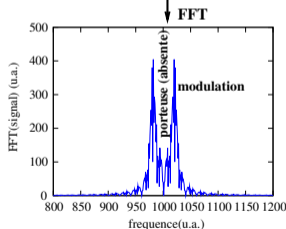
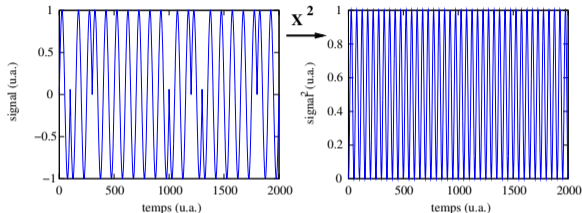

emission **reception**

1.21 GHz source

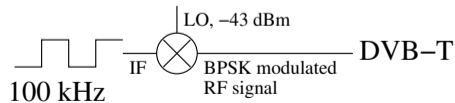

Porteuse issue de la mise au carré du signal BPSK

$$\cos(\varphi)^2 \propto \cos(2\varphi) \quad \varphi \in [0; \pi] \Rightarrow 2\varphi = 0[2\pi]$$

Démodulation de phase

Retrouver la porteuse dans GNU Radio (rétroactions interdites dans GNU Radio) : block disponible “boucle de Costas” :

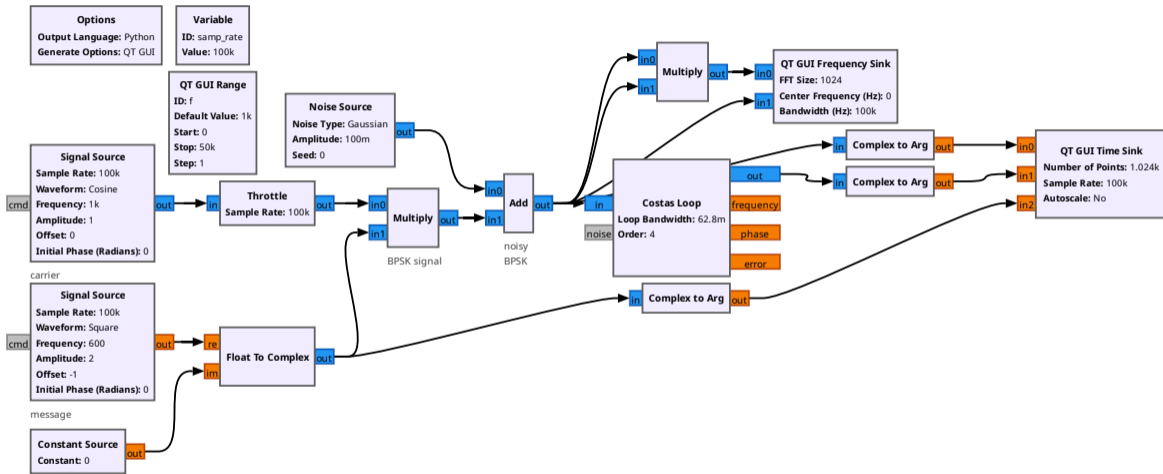

Carrier offset : $\Delta\omega$ + Modulation : $\varphi = [0; \pi] \rightarrow \sin(\underbrace{\Delta\omega \cdot t + \varphi}_{\text{sépare}})$

Application à RDS

- ▶ Signal RDS faible \Rightarrow contrôle de gain automatique (AGC)
- ▶ Compensation de l'écart entre oscillateur local et oscillateur distant qui porte RDS
- ▶ Phase cesse de tourner
- ▶ Diagramme de constellation

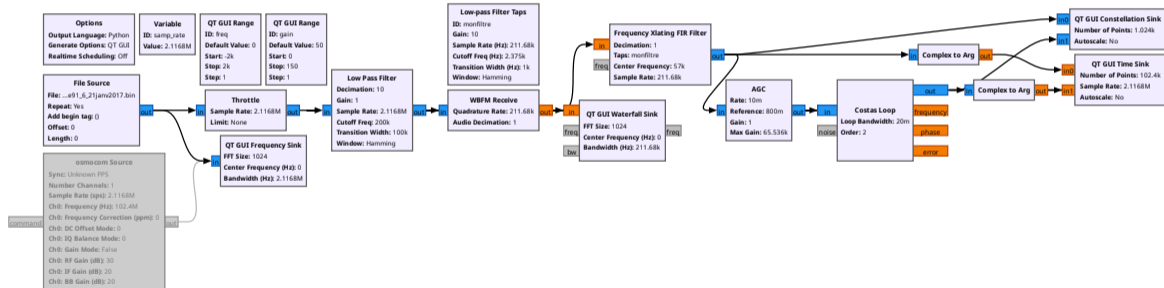

Synchronisation des symboles

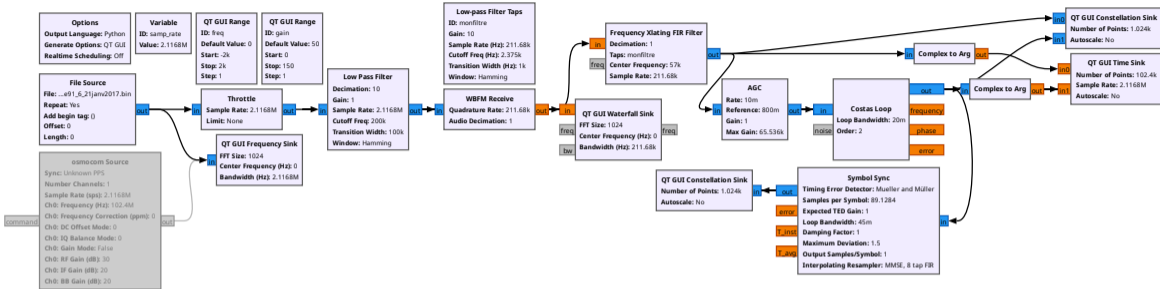

- ▶ Symboles numériques sont sur-échantillonnés
- ▶ Échantillons sur les transitions entre symboles numériques ($\text{phase} \in [0, \pi]$)
- ▶ Détecter les transitions et ne fournir en sortie que un échantillon par symbole sur l'état stable du signal numérique (attention : changement de débit)
- ▶ Codage différentiel : deux bits/symbole
- ▶ *Symbol Sync* : $\text{Samples per Symbol sps} = \text{samp_rate} / \text{DEC} / (1187.5 * 2)$

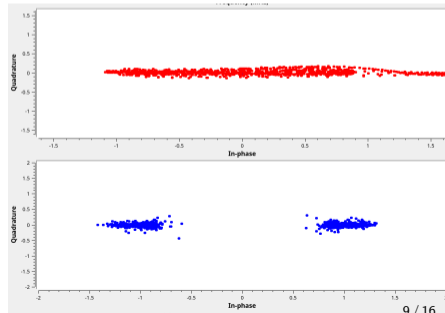

Synchronisation du flux de bits

Page 66
EN 50067:1998

ANNEX C (informative)

Implementation of group and block synchronisation using the modified shortened cyclic code

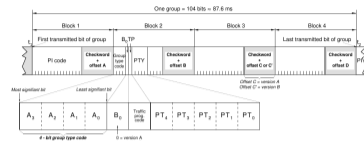

2.4 Synchronisation of blocks and groups

The blocks within each group are identified by the offset words A, B, C or D added to blocks 1, 2, 3, and 4 respectively in each group (see annex A).

The beginnings and ends of the data blocks may be recognized in the receiver decoder by using the fact that the error-checking decoder will, with a high level of confidence, detect block synchronisation slip as well as additive errors. This system of block synchronisation is made reliable by the addition of the offset words (which also serve to identify the blocks within the group). These offset words destroy the cyclic property of the basic code so that in the modified code, cyclic shifts of codewords do not give rise to other codewords [6, 7].

Further explanation of a technique for extracting the block synchronisation information at the receiver is given in annex C.

C.1 Theory

C.1.1 Acquisition of group and block synchronisation

To acquire group and block synchronisation at the receiver (for example when the receiver is first switched on, on tuning to a new station, or after a prolonged signal-fade) the syndrome s must be calculated for each received 26-bit sequence. That is, on every data-clock pulse the syndrome of the currently stored 26-bit sequence (with the most recently received data bit at one end and the bit received 26 clock pulses ago at the other) is calculated on every clock pulse.

This bit-by-bit check is done continuously until two syndromes corresponding to valid offset words, and in a valid sequence for a group i.e. [A, B, C (or D)], are found $n \times 26$ bits apart (where $n = 1, 2, 3$, etc.). When this is achieved, the decoder is synchronised and the offset words which are added to the parity bits at the transmitter are subtracted at the receiver before the syndrome calculation for error correction/detection is done (see annex B).

NOTES TO FIGURE 9:

1. Group type code = 4 bits (see 3.1)
2. B_0 = version code = 1 bit (see 3.1)
3. A_0 code = Programme Identification code = 16 bits (see 3.2.1.1 and annex D)
4. PT_0 = Traffic Programme Identification code = 1 bit (see 3.2.1.3)
5. PT_1 = Programme Type code = 5 bits (see 3.2.1.2 and annex F)
6. Checkword + offset "N" = 10 bits added to provide error protection and block and group synchronization

- ▶ Norme : utiliser le code cyclique redondant (CRC) pour identifier le début des phrases
- ▶ Recherche de position du premier bit pour lequel CRC correct pour les données qui le précèdent
- ▶ Alternative : utiliser le code unique attribué à chaque station FM (PI : *Program Identification*)
- ▶ Liste des PI disponible à <https://www.arcom.fr/radio-et-audio-numerique/radio-fm-dab>
- ▶ Norme : toutes les transmissions se font MSB en premier

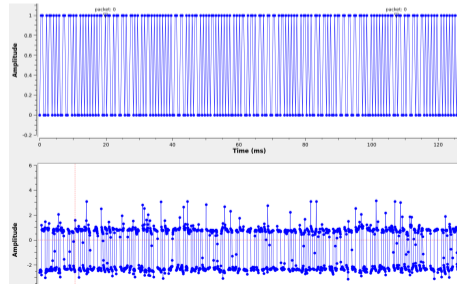

Post-traitement : Python Block

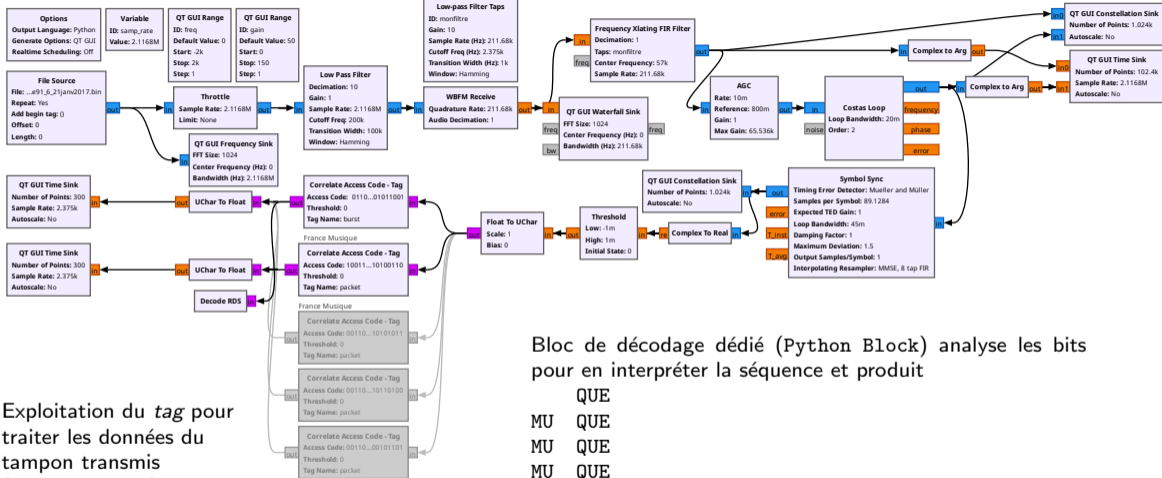

Exploitation du tag pour traiter les données du tampon transmis (excluant le tag)

Bloc de décodage dédié (Python Block) analyse les bits pour en interpréter la séquence et produit

QUE
 MU QUE
 MU QUE
 MU QUE
 MU QUE
 MUSIQUE
 MUSIQUE

Décodage des trames numériques de RDS

Extraits de EN 50067 *Specification of the radio data system (RDS) for VHF/FM sound broadcasting in the frequency range from 87,5 to 108,0 MHz*

3.1.5 Coding of the Group types

3.1.5.1 Type 0 groups: Basic tuning and switching information

The repetition rates of type 0 groups must be chosen in compliance with 3.1.3.

Figure 12 shows the format of type 0A groups and figure 13 the format of type 0B groups.

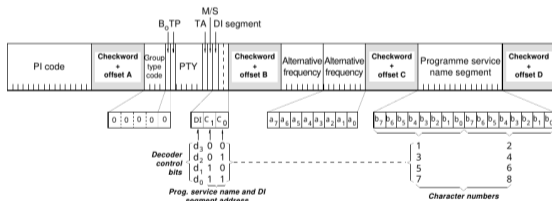

Figure 12: Basic tuning and switching information - Type 0A group

3.1.5.3 Type 2 groups: RadioText

Figure 16 shows the format of type 2A groups and figure 17 the format of type 2B groups.

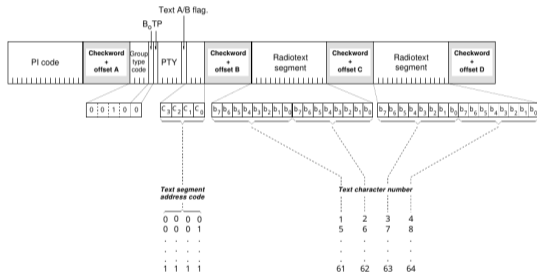

Figure 16: RadioText - Type 2A group

Leurrage de signaux RDS : D. Symeonidis, *RDS-TMC Spoofing using GNU Radio*, Proc. 6th Karlsruhe Workshop on Software Radios (2010), ou A. Barisani & D. Bianco, *Injecting RDS TMC Traffic Information Signals*, DEF CON 15 à <https://www.youtube.com/watch?v=xgGgRKi1CGo> et https://blackhat.com/presentations/bh-usa-07/Barisani_and_Bianco/Presentation/bh-usa-07-barisani_and_bianco.pdf

Conclusion

- ▶ Prise en main de GNU Radio (complexes v.s. réels, repliement spectral, filtrage et impact de la bande de transition sur ressources de calcul et retard)
- ▶ Applicable sur signaux synthétiques et réels
- ▶ Cas d'une communication numérique (RDS)
- ▶ Démodulation FM, transposition de la sous-porteuse en bande de base : constellation tourne
- ▶ Compensation de l'écart de fréquence (boucle de Costas) : constellation stable mais points reliés
- ▶ Synchronisation de symboles : constellation formée de points (*soft bits*) distincts
- ▶ Décision (*soft bits* → *hard bits*)
- ▶ Bits → phrases (mot de synchronisation, utilisation du CRC)
- ▶ Interprétation des phrases